



A Guide to Quick Installation

Three-phase Grid-tied PV String Inverter:

50K/60K



Please scan the two-dimensional code to download the APP

Quality Guarantee

Where otherwise agreed to in a contract, quality warranty period of the inverter is 60 months. The PV inverter defective or damaged within its quality warranty period shall be repaired or replaced for free. However, warranty or liability will be void if damage is caused from below operations/situations:

1. The warranty period expired;
2. The damage caused during transit;
3. The damage caused by force majeure including, but not restricted to the following: earthquake, flood, fire, explosion, debris flow etc;
4. Operation in adverse environments beyond that described in User Manual;
5. Any installation and operation environment beyond the relevant national standards;
6. Any installing, reconfiguring, or using faulty;
7. Any revising the product or modifying its software code without authorization;
8. Maintenance faulty caused by the technician personnel unauthorized;
9. Any operation ignoring the safety precautions stipulated in User Manual;

Symbol Conventions

Read through the safety symbols used in this manual, which highlight potential safety risks and important safety information, before using the inverter

Symbol	Description
	DANGER Indicates an imminently hazardous situation which, if not correctly followed, will result in serious injury or death.
	WARNING Indicates a potentially hazardous situation which, if not correctly followed, could result in serious injury or death.
	CAUTION Indicates a potentially hazardous situation which, if not correctly followed, could result in moderate or minor injury.
	NOTICE Indicates a potentially hazardous situation which, if not correctly followed, could result in equipment failure to run, or property damage.
	NOTE Calls attention to important information, best practices and tips: supplement additional safety instructions for your better use of the PV inverter to reduce the waste of your resource.

Outline and Dimensions

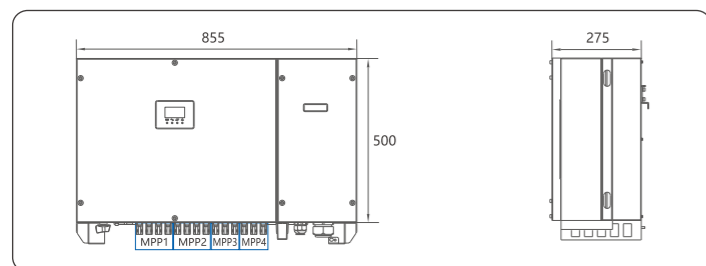

Route connecting for PV strings installation

Route connecting for the installation of PV strings per inverter model is shown in below table: 50K totally 10 routes and 60K totally 12 routes.

Model	MPPT1	MPPT2	MPPT3	MPPT4
50K	3 routes	3 routes	2 routes	2 routes
60K	3 routes	3 routes	3 routes	3 routes

Installation

The deliverables in the fittings of inverter

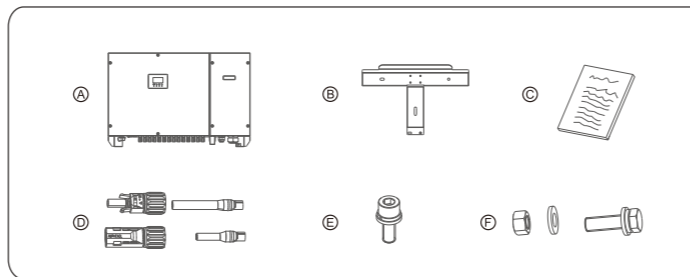

Items	Deliverables
A	The inverter
B	Rear panel
C	File package
D	DC terminal connector group 50K(10*2)/60K(12*2)
E	M6 screw
F	Bolt group (including screw, nut)*3 (reserved for tightening the support and rear panel)

Determining the Installation Position

The inverter must be installed on the place where is free from direct exposure to sunlight, rain, and snow to extend its service life.

Installation Space Requirements

Reserve enough clearance around the inverter to ensure sufficient space for installation and heat dissipation, as shown in below Figure. When installing multiple inverters, ensure 400mm distance between inverters' lateral sides, 600mm between inverters' top and/or bottom sides, and 1000mm clearance between inverters' front sides.

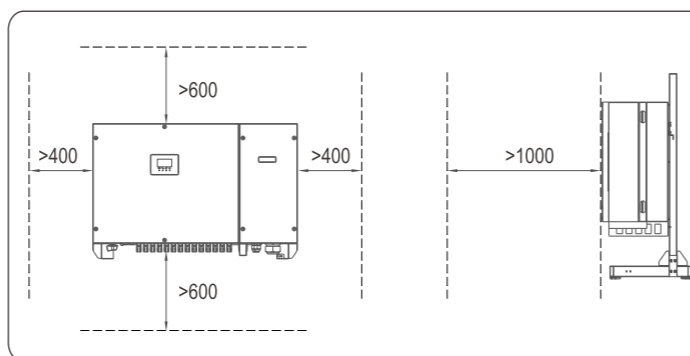

Support-mounting the Inverter

Step 1 Support-mounting the inverter is recommended. Tighten the support and rear panel using M12 bolt and the required torque is 42N.m.

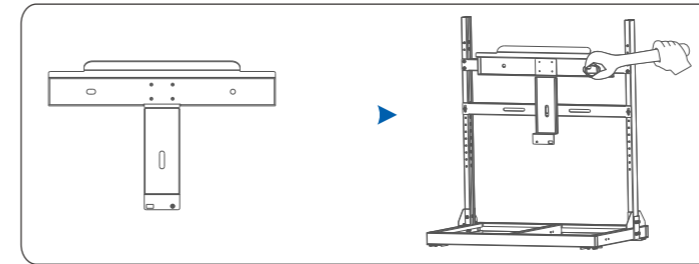

Step 2 Mount the inverter on the rear panel and tighten the inverter with the rear panel by locking screws at the bottom of the inverter.

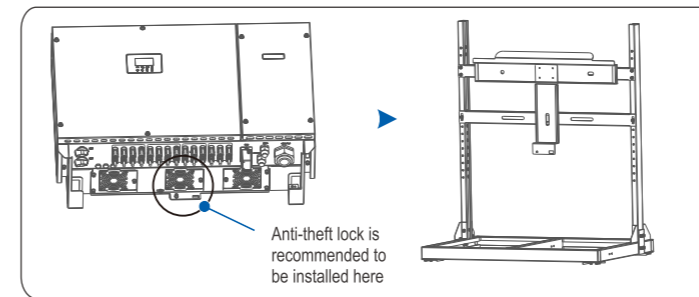

Installation Self-check

1. Ensure that the three supporting points (on the rear side of the inverter) align with the three holes of the support
2. Ensure that the inverter is well fixed
3. Ensure that the inverter is locked on the support and an anti-theft lock is installed

Preparation before wiring

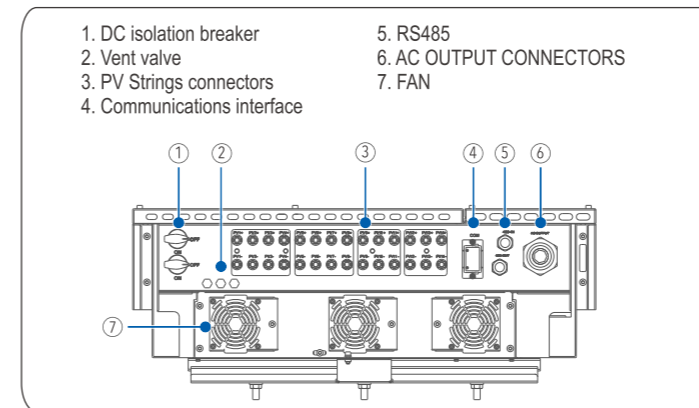

Electrical Connections

	DANGER Before performing any electrical connections, ensure that both DC and AC Switches are OFF. Otherwise, fatal injury can occur due to the high voltage caused from AC and DC cables.
	CAUTION Grounding the PV Strings needs below prerequisites.
An isolation transformer must be installed on the AC side of each inverter; Ensure that the neutral wire of the isolation transformer must be disconnected from the PGND cable.	
One isolation transformer is with one PV inverter: do not install a single isolation transformer for multiple inverters; otherwise, circulating current generated by the inverters will lead to operation failure.	
Select "Isolation SET" on the APP, and set in "Input Grounded", "With TF".	

Cable specifications (recommended)

	Cable type	Cross-sectional Area of single strand (mm ²)	Recommended OT terminals	notes
AC terminal	5-core outdoor special cable	30~50	OT35~50-8	The distances between AC terminal and gridconnection is no more than 200m.
	4-core outdoor special cable			
Protection Ground (PGND) Cables	multi-core outdoor special cable	30~50	OT35~50-6	Terminal connection

AC circuit breaker

Connect the inverter with the power grid through installing one AC circuit breaker whose rated current is no less than 100A. Residual current protection function of square matrix is internally installed in the inverter and you can set leakage current protection value no less than the corresponding value in below table, if local utility department require leakage current protection function for AC circuit breaker. That set can save the inverter from its performance failure.

Inverter Model	Residual current value
50K	500mA
60K	600mA

Connecting AC Output Cables

AC output cables connection is operated within the right case. Before connection AC cables, you need loosen these four screw locks using socket hexagon wrench, take out the wire connecting with Earth wire using cross screwdriver, and remove the cover of wiring chamber. Please follow below steps to connect AC cables for the sake of your personal and property safety.

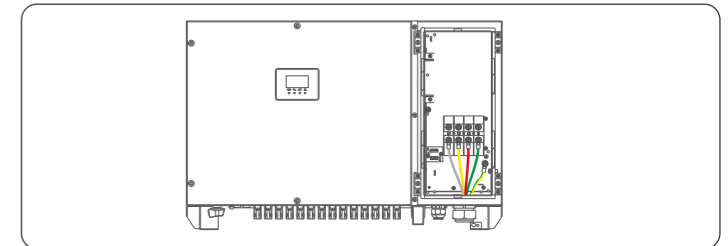

AC Wiring Procedure

- Step 1 Remove an appropriate length of the jacket and insulation layer from the AC output cable. Insert the exposed core wires into the crimp area of the OT terminal, wrap the wire crimp area with heat shrink tubing or insulation tape, and crimp them using hydraulic pliers.
- Step 2 Loosen the locking cap from the AC OUTPUT waterproof cable connector at the bottom of the inverter and remove the plug from the locking cap.
- Step 3 Route the AC output power cable into the locking cap and the AC OUTPUT connector at the inverter bottom, and connect the AC cable to L1, L2, L3, N, and E on the AC terminal block, tighten them using screw driver and the required torque is 12 N.m.
- Step 4 Tighten the locking cap on the AC OUTPUT waterproof cable connector to a torque of 12 N.m.
- Step 5 Tighten the four screws on the cover to a torque of 3 N.m.

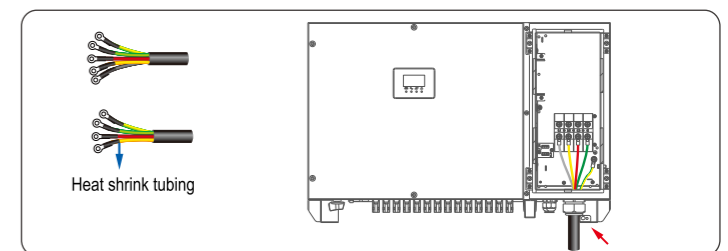

	NOTICE For your operation and safety sake, please prepare multi-stranded wire, crimping terminals and a proper crimping tool before AC Wiring.
--	---

Connecting the PV Strings

- Step 1 Remove an appropriate length of the insulation layer from the positive and negative power cables using a wire stripper, as shown in below Figure.
- Step 2 Insert the exposed areas of the positive and negative power cables into the metal terminals of the positive and negative connectors respectively, crimp them, and tighten the locking nuts on the positive and negative connectors using a removal wrench.
- Step 3 Take out the protective plug from the DC terminals of the inverter, insert the positive and negative connectors into the corresponding connector terminals of the inverter until a "click" sound is heard.

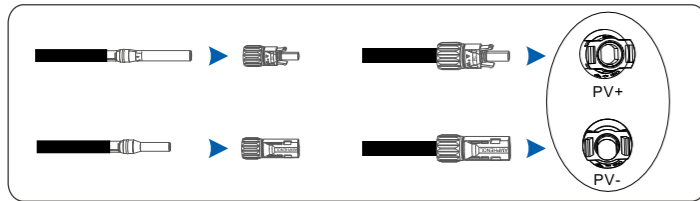

WARNING When taking out DC connectors, please ensure that PV Strings are disconnected; otherwise, a fire can occur.

Refer to No. of DC input terminals at the bottom of inverter shown in below figure: 50K with 10 routes and 60K with 12 routes, if quantity of PV strings is less than number of input on inverter, you can refer to below Table for the installation of PV strings and the inverter.

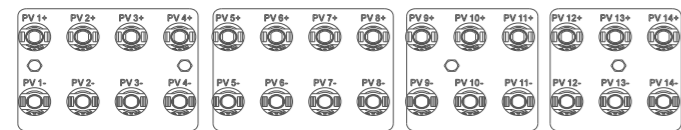

Input Route	Number of Input Route	Inverter model
1	Connected to any route	50K/60K
2	Connected to routes 2 & 6	
3	Connected to routes 2, 6 & 10	
4	Connected to routes 2, 6, 10 & 13	
5	Connected to routes 2, 3, 6, 10 & 13	
6	Connected to routes 2, 3, 6, 7, 10 & 13	
7	Connected to routes 2, 3, 6, 7, 10, 11 & 13	
8	Connected to routes 2, 3, 6, 7, 10, 11, 13 & 14	
9	Connected to routes 2, 3, 4, 6, 7, 10, 11, 13 & 14	
10	Connected to routes 2, 3, 4, 6, 7, 8, 10, 11, 13 & 14	
11	Connected to routes 2,3, 4, 6, 7, 8, 9, 10, 11, 13 & 14	
12	Connected to routes 2, 3, 4, 6, 7, 8, 9, 10, 11, 12, 13 & 14	

Inverter Uninstall

Inverter uninstall requires below procedure:

- Step 1 Disconnect all electric connections including these of communications cables, DC input cables, AC output cables and the PGND cables.

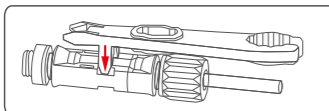

When uninstalling DC input connectors, insert removal wrench into the bayonet shown in Figure, press the wrench down, and take out the connector.

- Step 2 Remove the inverter from its rear panel.
- Step 3 Remove the rear panel.

WARNING Before uninstalling DC input connector, please ensure that the DC SWITCH is set to OFF to avert equipment damage and/or personal injury.

System Operation

Switch ON the AC circuit breaker and set the DC SWITCH of the inverter to ON. Observe statuses of grid-connecting light on the inverter for a while, and if the lights display that the inverter has entered gridconnecting, it means the inverter is operating well. Any query during operating the PV inverter, call your dealer.

To power OFF the Inverter, switch off the circuit breaker at AC terminal, and set the DC SWITCH to OFF.

WARNING After the inverter power is off, the remaining electricity and heat may still cause electrical shock and body burns. Please only begin servicing the inverter ten minutes after the power-off.

Interface

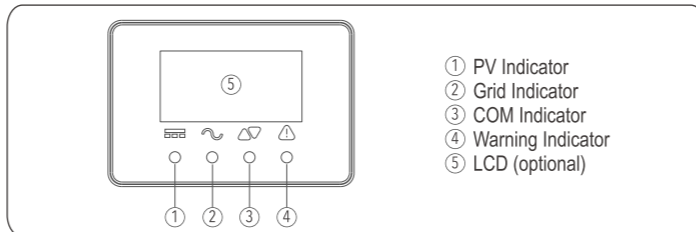

LED Indicator

LED indicator	status	descriptions
PV Indicator	on	Voltage of PV strings meets the requirements for inverter grid-connecting to generate power.
	blink	Voltage of PV strings can't meet the requirements for inverter grid-connecting to generate power.
Grid Indicator	blink	Power grid abnormal, and can't meet the requirements for inverter grid-connecting to generate power.
	on	When grid-on, the blink (every cycle last 30s) of Grid Indicator means loading amounts: quantity of blink means power size, and after that the Indicator keeps ON. When less than 20% rated power, blink one time; 20%~40% rated power, blink twice every 30s; 40%~60% rated power, blink three times every 30s; 60%~80% rated power, blink four times every 30s; 80%~100% rated power, blink five times every 30s.
COM Indicator	blink	Communications data transmission is underway.
	off	No external communications is connected or no communications data transmission.
Warning Indicator	on / blink	Refer LED status in warning table
	off	No warning

LCD Screen

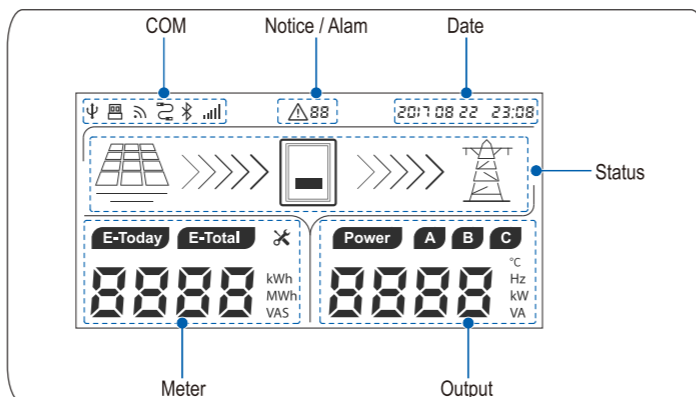

LED status and Warning code

	Warning code	PV indicator	Grid indicator	COM indicator	Warning indicator
Normal status		●	●/★	◎	○
Starting up		●	○	◎	○
WLAN/WIFI/RS485 communication		◎	◎	★	○
PV normal		●*	◎	◎	○
Grid over voltage	A0				
Grid under voltage	A1				
Grid absent	A2				
Grid over frequency	A3	◎	★	◎	○
Grid under frequency	A4				
Grid unbalance	A6				
PV over voltage	B0				
PV under voltage	B4	★	◎	◎	○
Weak radiation	B5				
Strings abnormal	B3				
Inverter over temperature	C5	◎	◎	◎	★
Fan abnormal	C8				
Insulation resistance abnormal	B1	●	○	○	●
Leakage current abnormal	B2	○	●	○	●
Strings reverse	B7	○	○	●	●
Control power abnormal	C0	○	★	○	●
DC bias current abnormal	C2	★	●	★	●
Inverter relay abnormal	C3	○	●	●	●
Leakage current HCT abnormal	C6	●	●	○	●
System fault	C7	★	★	★	●
DC link voltage unbalance	C9	●	○	●	●
DC link over voltage	CA	○	●	★	●
Internal Communications Fault	CB	○	○	★	●
Software version incompatibility	CC	★	●	○	●
EEPROM fault	CD	★	○	●	●
Sampling inconsistency	CE	★	●	●	●
Invert circuit abnormal	CF	●	●	●	●
Boost circuit abnormal	CG	★	○	○	●

Note: ● light on ○ light off ★ light blink ◎ keep original status

Connecting RS485 Communications Cables

Installing RS485 communications cable procedure

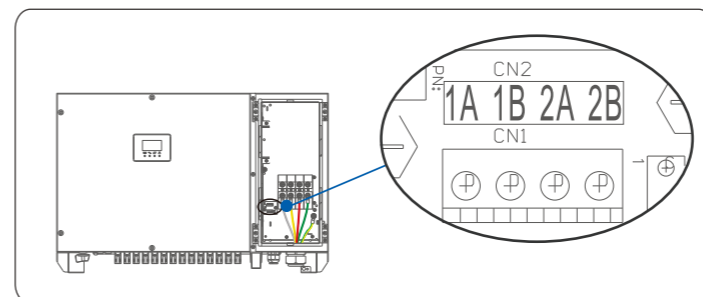

Interface of RS485 communications cable is in the right case of the inverter, shown in above figure.

- Step 1 Remove the wiring chamber on the right of inverter, and loosen the locking cap on 485 waterproof cable connector from the bottom of inverter.
- Step 2 Remove an appropriate length of the insulation layer from the communications cable, loosen screw lock to take out panel, insert the cable to the waterproof cable connector, and tighten the locking cap.
- Step 3 Connect RS485 differential positive and negative signal of data logger to terminal 1A and 1B of inverter, and connect terminal 2A and 2B of the inverter to terminal 1A and 1B of another inverter.

Terminal resistance setting

Terminal resistance setting is built in the inverter. In case when one RS485 cable connects with multiple inverters or total length of communications cable is too long that communications is abnormal, you need set ON the terminal resistance of RS485 communications from the inverter connected at the end of chain.

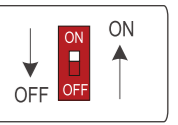

Modbus Address setting

When V1000 data collector logger is equipped with the inverter, Modbus address can be automatically allocated. And when other brand data collector logger is used, you need download APP and set Modbus address according to below figure.

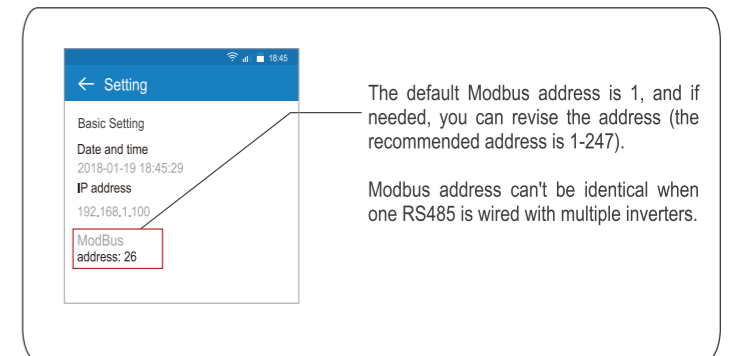

Maintenance

Check periodically heat sink and the inlet / outlet of external FAN, clean them, and ensure that they are free from dust and blockage. If any abnormal with the FAN, please replace it.

PV FUSE is in-built, if any warning display that the FUSE is melt, disconnect AC breaker, and switch off DC switcher to OFF; pull out all DC input strings, wait at least 10 minutes after the inverter is powered off. Then open both right and left frontal panels of the inverter, identify the melt FUSE using multi-meter, and replace them, install the panels, tighten the screws of invert, and restart the inverter.

DANGER When replacing the FUSE, be sure to unplug all the dc input group terminals of the inverter, otherwise there will be a danger of electric shock.

The Inverter Troubleshooting

If any abnormal phenomena occur, refer to below table for trouble shooting. If failed, call your dealer for help.

Issue	Solution
No display	1. Check DC switch of inverter is on or off 2. If there is PV combiner box, check fuse, terminal, wires
No generation	1. Check AC breaker is on or off 2. Wait stronger sunshine 3. Check the number of PV panel 4. To operate according to inverter's manual
Inverter abnormal	1. Disconnect both AC and DC breakers 2. Wait as less 10 minutes and switch on AC and DC breaker 3. Check whether inverter run normally or not
Power generation is less than expected	1.Ensure that inverter is free from direct sun exposure and good ventilation 2.Check that inverter isn't dust clogging, fans run normally 3.Ensure enough installation distance between inverters